











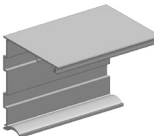

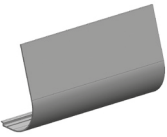



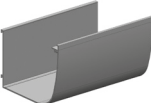



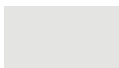

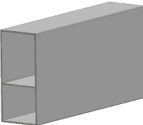
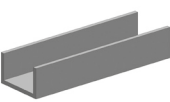

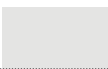

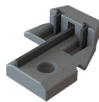

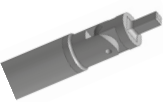

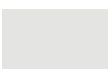

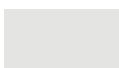
MOUNTING INSTRUCTIONS

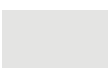
SLIDING ROOF SLIDING SERIES

acristalia
efficient glass enclosures

IDENTIFICATION OF PIECES

| | | | | | |
|---|---------------------------------------|---|---|---|---|
|  | WALL PROFILE S3/S5 |  |  | RAFTER SEAL |  |
|  | MOTOR COVER |  |  | REAR SLIDING SKID (RIGHT) |  |
|  | RAFTER |  |  | REAR SLIDING SKID (LEFT) |  |
|  | LINTEL AND LINTEL ANGLE PROFILE |  |  | LOWER LEFT REAR SLIDING SKID PANEL 1 |  |
|  | GUTTER |  |  | MACHINED SLIDING SKID |  |
|  | GUTTER ENDING CAP |  |  | RIGHT FRONT SLIDING SKID |  |
|  | DRAINAGE FOR GUTTER |  |  | LEFT FRONT SLIDING SKID |  |
|  | PANELS |  |  | UPPER STOP AND LEFT CAP |  |
|  | PILLARS |  |  | UPPER STOP AND RIGHT CAP |  |
|  | PILLAR U ANCHOR |  |  | LEFT WINDBREAKER |  |
|  | MOTORS |  |  | RIGHT WINDBREAKER |  |
|  | STICKS |  |  | GUTTER ENDING CAP |  |
|  | MOTOR-COVERING BLOCK |  |  | SCREW "A" 5,5 X 16MM |  |
|  | WALL PROFILE SEAL |  |  | SCREW "B" 3,5 X 9,5MM |  |
| | | |  | SCREW "C" 4,2 X 13MM |  |
| | | |  | SCREW "D" M6 X 20MM |  |
| | | |  | SCREW "E" 4,2 X 16MM |  |
| | | |  | SCREW "F" 3,5 x 13mm |  |

Once checked and identified, the list of components both in quantities and in lengths, we check the position of the profiles in the following image.

PROFILES POSITION

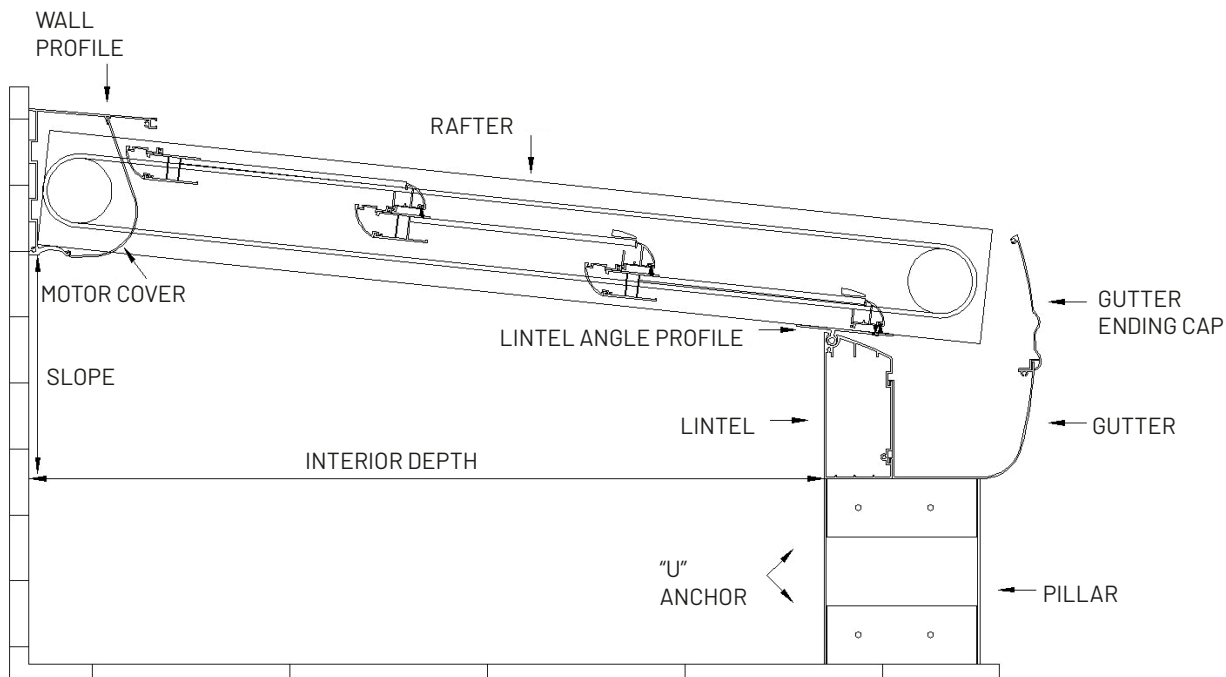

STEP 1:

- On the order form, check the height where we are going to fix the wall profile (high or low part) and start the fixing (we are going to add as much holes as we need to obtain a good moistening).

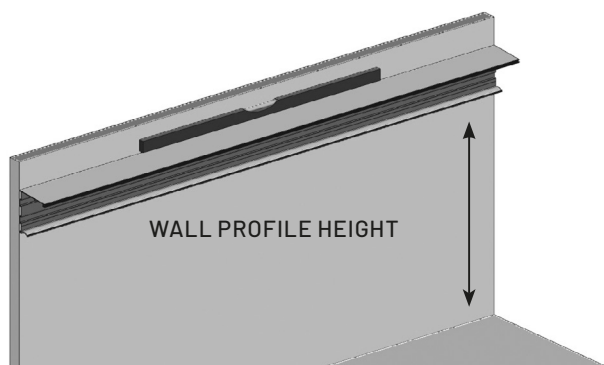

STEP 2:

- View the order form; we are going to mark (measure) the place of the lintel in relation with the wall profile, whatever the depth is (interior or total). It's important that this measure is correct, so that the panels are well placed on the lintel angle profile. After being marked, you can start fixing the anchoring plates on the ground, and then put them together for a good fastening. For the pillars fixations, we will use the screw "A".

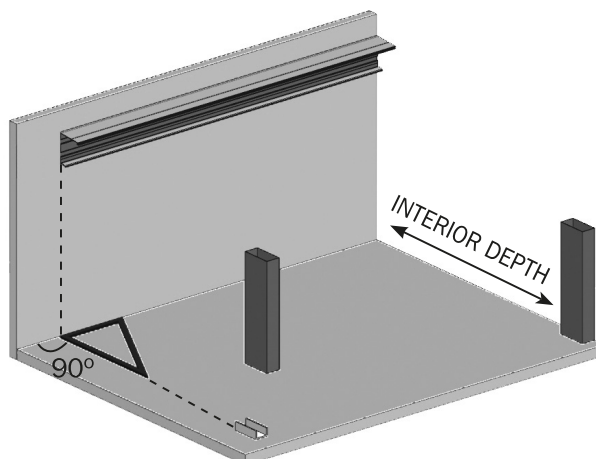

STEP 3:

- The pillars are already fixed on the lintel, but if you want one more, you should specify it on the order form. Then, place the lintel along the pillars line and put laterally each of them firmly towards anchors, with the screw A.

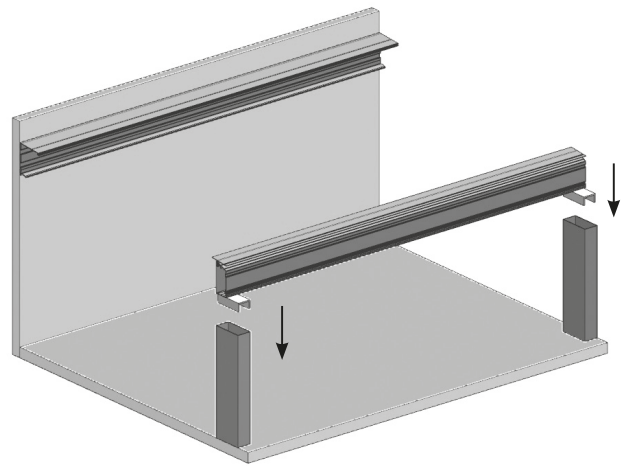
**STEP 4:**

- When the pillars are fixed, place the rail beams of the roof. First, we will identify the beams, and the bottoms will have taps marked with the logo of the company (numbered 1,2,3...). Always look at the roof from the front and from the left to the right side.

STEP 5:

- In the wall profile, insert the fixing cubes of the rafters. Once the rafter is supported by the lintel angle profile and makes contact with the wall profile, tighten the allen screw. Once the beam is fixed, it is necessary to fix the "A" screw in order to join the cube to the beam.

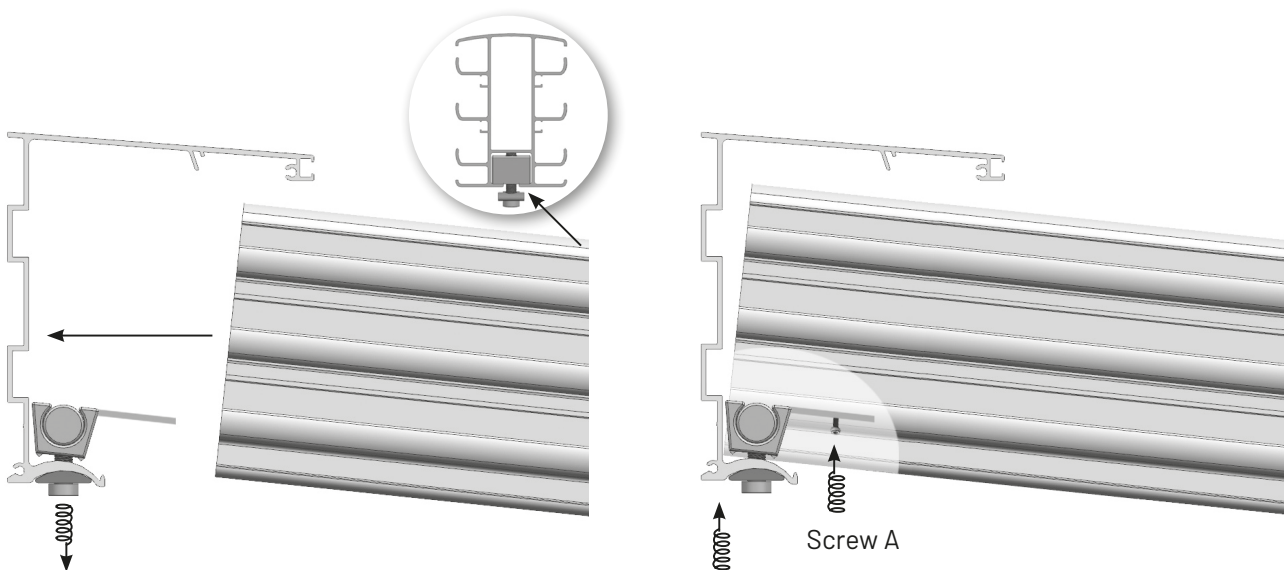

STEP 6:

- Once the upper part of the rafter is fixed to the (wall profile), proceed to the regulation of the lower part. First, we will place the fixing cubes located into the rafters, and unscrew the Allen screw from the beam fixing cube and its (WASHER). We will slide the cube so the drill of the lintel angle profile fits the thread of the fixing cube. Then insert the allen screw with its washer until it is fixed. We will take advantage of this step to plumb the pillars. We will do this process with all the rafters. Verify that the distance between the regular plate and the head of the rafter is of 80 mm. As in the previous step, **it is very important to fix the cube to the rafter through the screw "A"**.

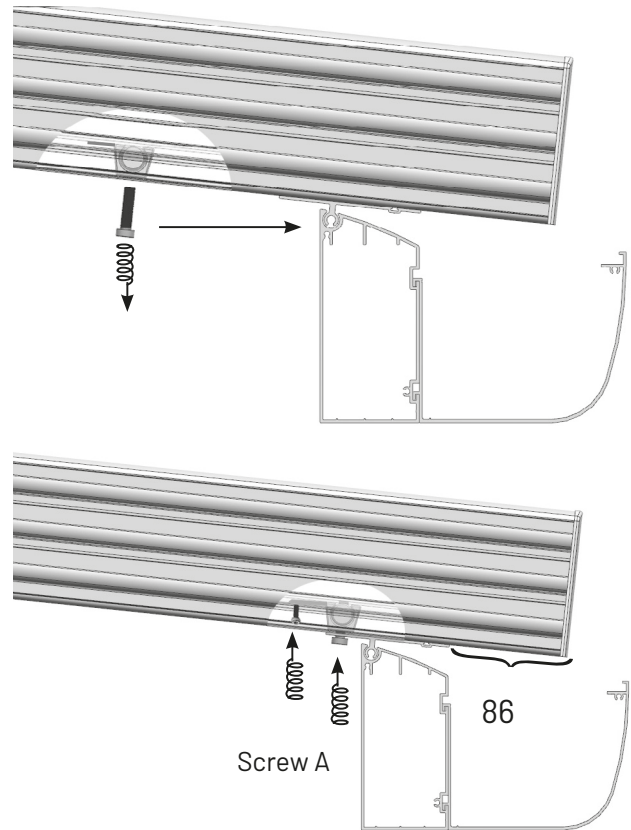
**PANELS' IDENTIFICATION****Panel 1:**

It is the panel placed at in the highest part of the rafter. We identify it as it is larger than the others.

WARNING!! THE REAR SLIDING SKIDS OF THOSE PANELS ARE THOSE WHO ARE REDUCED. THEY WILL BE IDENTIFIED IN ANOTHER BOX.

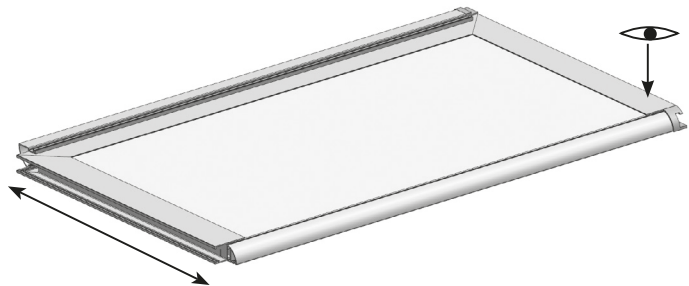
**Panel 2:**

They are identified for not having a machining on the top for the upper stop pieces.

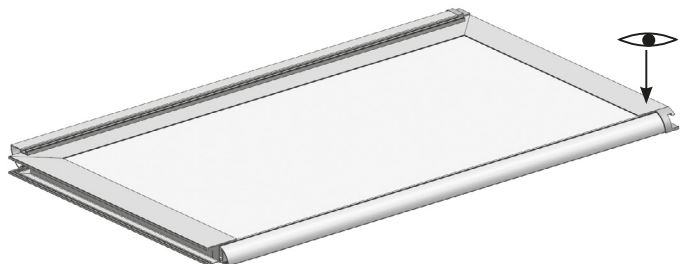
**Panels 3 and 4 (in case of S5 series).**

They are identified for having a machining on the top for the upper stop pieces.

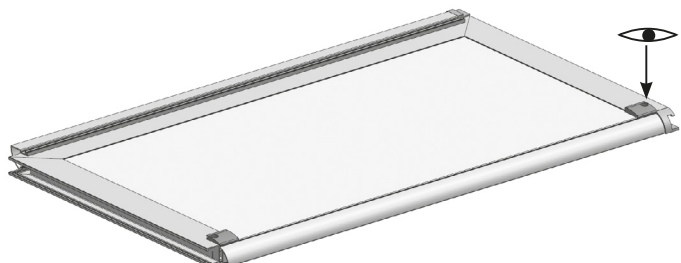

Panel 3 in the S3 series, and panel 5 in the S5 series:

It is the panel placed at the lower part of the rafter. We identify it because in case of being a motorized roof, it has a machining at the back of the panel for the anchorage ending cap of the piece that connects the panel to the clamp of the belt. In case of being a manual roof, the fixation props will be visible through the rear sliding skids.

PANELS' INTRODUCTION

STEP 7:

- In the case of motorized roofs, before introducing the panels, we have to make sure that the clamp of the belt is at the top part of the rafter. Once verified this, introduce the panel 1 at the highest part of the rafter by introducing first the side that does not have sliding skids.
- Later, move laterally the panel up to fitting it into the other rafter.

STEP 8:

- Now introduce the front and rear sliding skids (raising a little bit the panel) and fix them with the screw C. The front sliding skids have to be fixed through the low part of the panel and the rear ones through the top part. Repeat this process in each panel.

STEP 9:

- Move the panels manually up to the top part where we will proceed to fix the upper stops to each one of the panels with the screw D. **WARNING, THE UPPER STOPS KEEP LEFT AND RIGHT HAND. THEY ONLY FIT IN ONE POSITION.**

Motorized

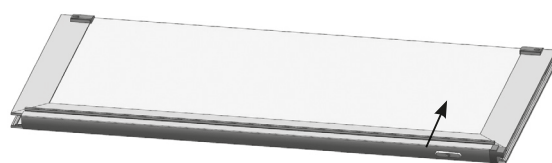

Manual

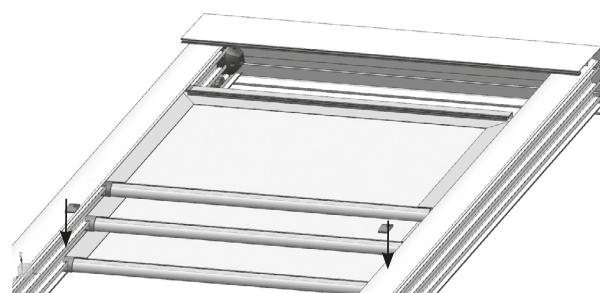
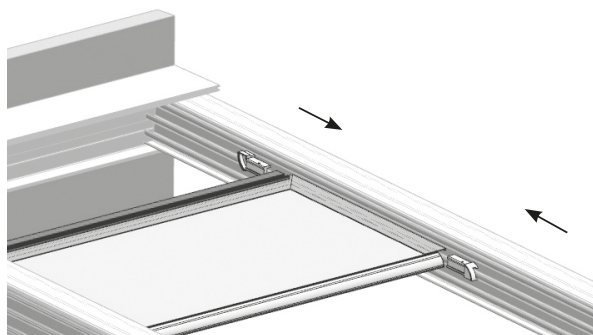
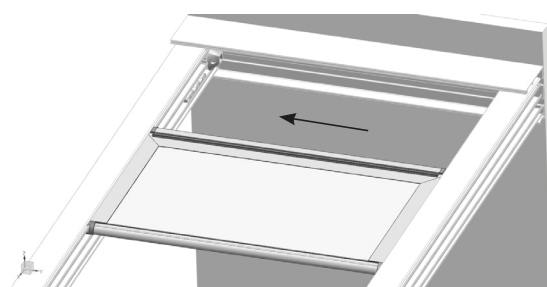
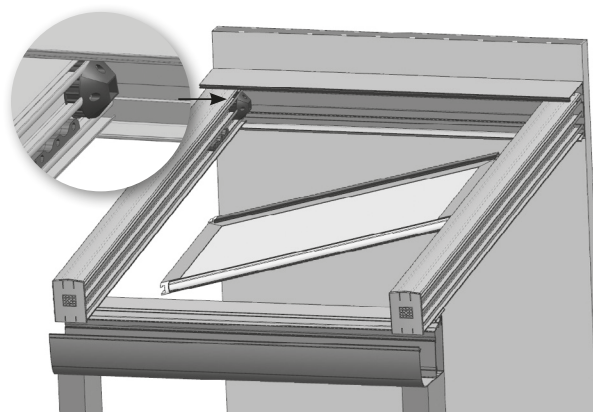
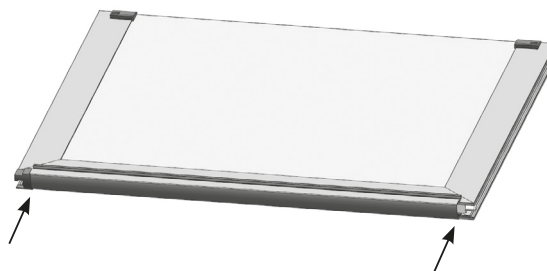

MOTORIZED ROOF

CLAMPING OF PANEL 3 OR 5 TO THE BELT

STEP 10:

- Move the belt clamp up to the back of the panel. Remove the piece fitted into the machining and move the inner piece until it is introduced into the hole of the belt clamp. Then, reintroduce the ending cap previously removed and fasten it with the screw B.

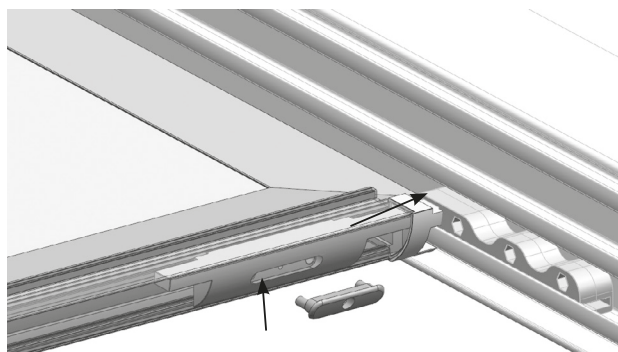

MOTOR'S INSTALLATION

The motors are already introduced into their corresponding pipes and with the required accessories necessary for their installation.

STEP 11:

- In one of the rafters there is a metallic plate installed at the back part of the rafter. The base of the motor has to be perfectly fitted inside.

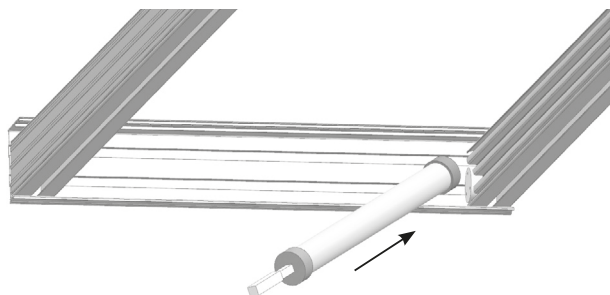

STEP 12:

- Immediately afterwards, we move the piece found in the head of the motor until it is completely introduced in the pulley. Block the piece with a cotter pin in order to prevent this piece from leaving.

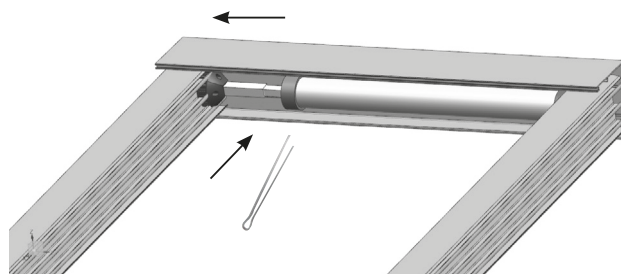

IMPORTANT!!

Before fixing the panel 1 (top panel), regulate the upper and lower stops of each motor.

***Once you came at his stage, check the motor programming in the box of accessories.**

MOTORIZED AND MANUAL ROOF

PANEL 1 FIXATION

STEP 13:

- To proceed to the fixation of the panel 1, make sure that the brush of the lowest panel is the same as the lintel angle profile one (see image). Then, take the upper panel at the highest position allowed by the system. Mark the position where it is and open the roof in order to have access to the top part to fix it. Join the panel to the rafter with the screw E through the top part of the rafter and as fitted as possible to the wall profile so that the water rubber seal of the wall profile covers the screw previously mentioned.

In case of having a system with 2 or 4 panels

Once the top panels are fixed, fix the tube 40x20 supplied as seen in the photo. So that the water rubber seal of the wall profile remains installed ahead of this tube (see following point).

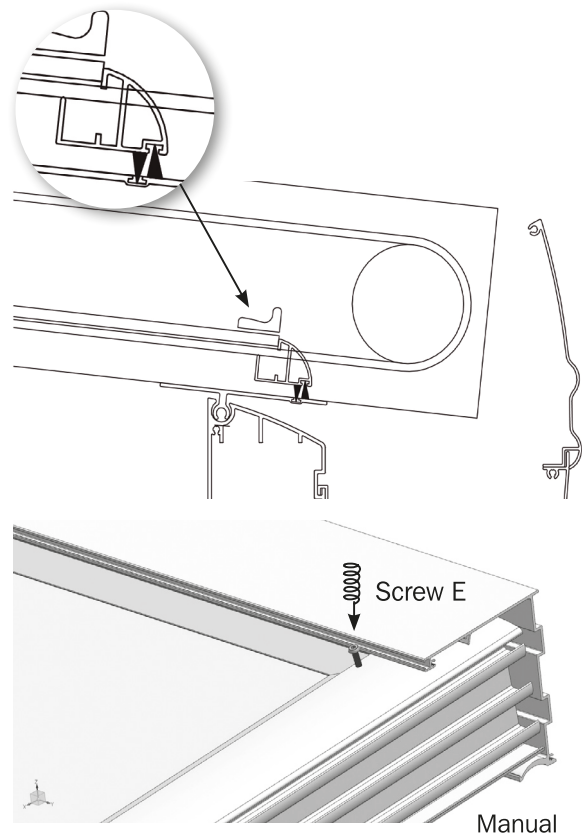

SEALS INSTALLATION

STEP 14:

- Once the panels are fixed, proceed to the installation of the seal of the wall profile that will come under pressure as shown on the image.
- Then, install the seals in the rafters by introducing the pressure in the seal carrier that we find on the rafter at the top of the panel, like the picture shows. The seals stick out of the panel between 5 and 10 cm and have to be introduced under the top panel approximately 2 cm. The highest panel will have to go sealed laterally to the rafters. The seals of the lowest panel will be identified, due to the fact that they are shorter than the rest. Once installed all the seals, open the roof and fix each seal at its ends with the screw F.

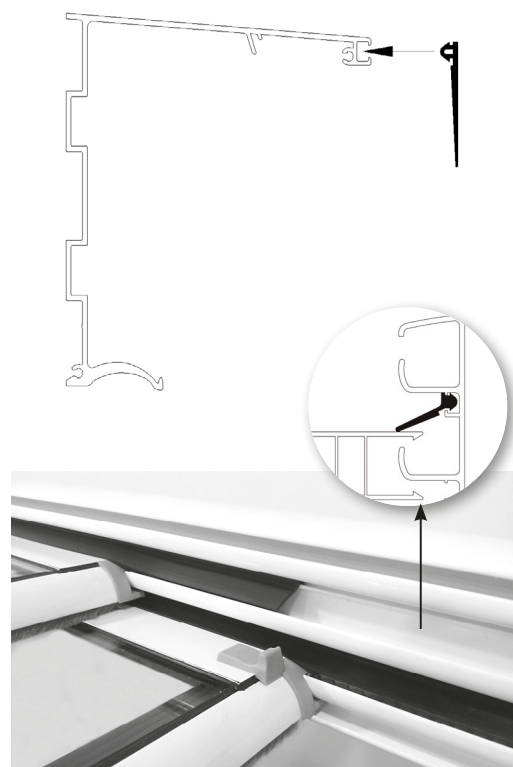
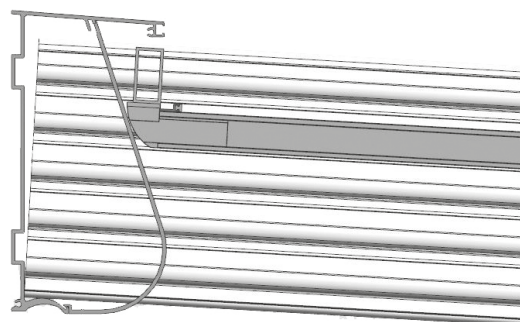

WINDBREAKERS INSTALLATION

STEP 15:

To end with the installation of the sliding roof, proceed to the fixation of the angle profile windbreakers.

- Fix the windbreakers with a DIN982 3'5X13 screw. As shown in the following pictures, each row shall include one right windbreaker and one left windbreaker.

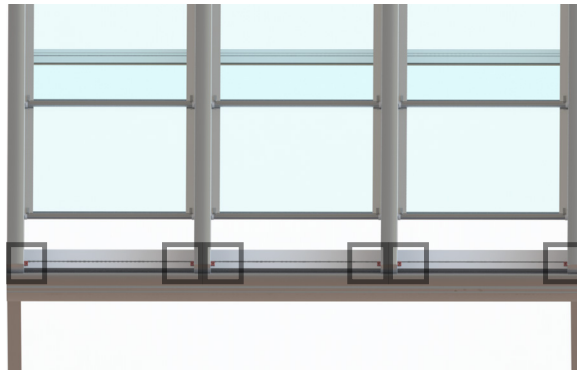

- The parts are flush with the angle profile brush

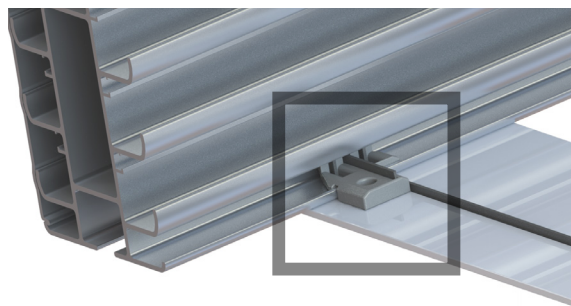

- Once the roof is closed, the last panel must remain on the windbreaker.

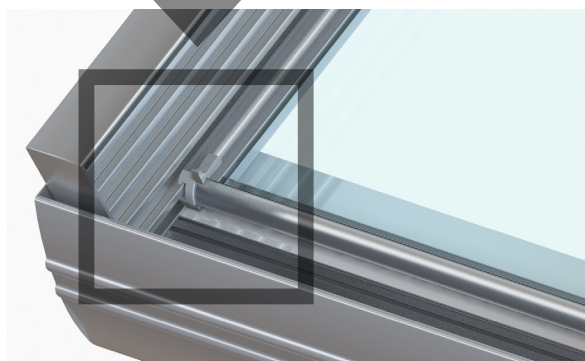
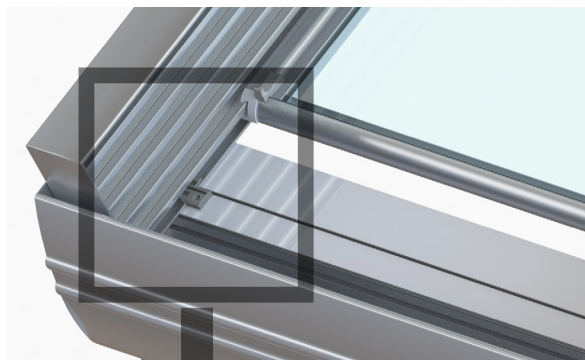

MOTOR-COVERING BLOCK: MOUNTING INSTRUCTIONS

Once the roof is installed and the coverings of the motors are placed too, block them using this new part. To do so, introduce a Allen 4 key in the holes of the motor covering and screw the stud that is inside the motor-covering block part, until the profile is well blocked. Four turns will be sufficient. Here is the process explained with pictures:

