

SERIES 641F SPECIFICATIONS

Firewall, Individual, Omni-Directional Panels

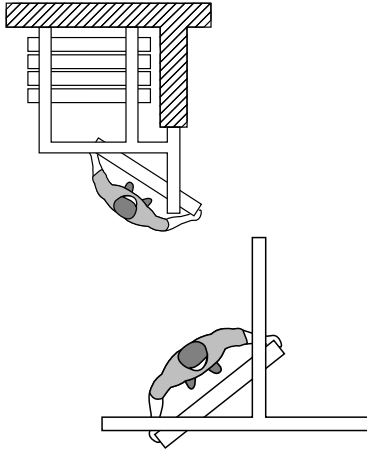

**Top Supported
Side Stack
Individual, Omni-Directional Panel
Manually Operated**
Maximum Opening Height: 40'5" [12.3m]
Maximum Opening Width: Unlimited
STC Ratings: 51 or 54

PRODUCT OVERVIEW:

Select for Durability & Fire Protection: These rugged steel panels resist daily wear and tear and have a one-hour fire rating. They are an excellent choice for meeting rooms, heavy-use facilities, or wherever local codes require a fire rated partition.

Standard Features: Steel frame, 4" [100] nom. thickness, no vertical trim, one-piece steel face, retractable top and bottom seals.

Individual, Omni-Directional Panels: Individual, manually operated panels offer maximum room flexibility. The track system enables panels to negotiate turns and curves and be used in alternate locations.

How to Obtain: Hufcor partitions are sold, installed, and serviced by factory-trained local authorized Distributors in the United States and by Licensees and Distributors outside the U.S.A.

Delivery: Panels are custom built for your specific project. Lead times vary due to seasonal fluctuations (average 6-8 weeks from receipt of final dimensions). Check with your Distributor for the current schedule.

Warranty: Track and panels are guaranteed for **two years** against defects in material and workmanship.

"Standard" Product Features and Benefits:

Look for these features when comparing similar products.

- Feature:** One-hour fire rated
Benefit: Complies with local code requirements.
- Feature:** Fire and sound rated
Benefit: Fire protection with no loss of sound control.
- Feature:** One piece steel face
Benefit: Optimum acoustics; no unsightly horizontal butt joints.
- Feature:** No vertical trim
Benefit: Provides a monolithic look.
- Feature:** Quick-set retractable top & bottom seals
Benefit: Retractable seals accommodate out-of-level floor conditions; provide constant force for consistent sound control and stability when the seals are set. When retracted, nothing drags on the floor or track when the panels are moved. Panels can be "locked" in place.
- Feature:** Minimum 110 lb. [50 kg] seal force when seals are set.
Benefit: Maintains panel stability and optimum acoustics.
- Feature:** Waist high seal activator
Benefit: Fast, easy seal activation without bending or stooping.
- Feature:** Removable operating handle
Benefit: Prevents unauthorized operation.
- Feature:** Expanding Jamb Closure (Lever Closure) Panel
Benefit: Exerts 250 lbs [113.4 kg] of force against the fixed wall. The compression creates tight panel joints for optimum sound control.
- Feature:** Interlocking vertical seal
Benefit: Helps panel-to-panel alignment and prevents sound leaks between panels.

Optional accessories enable the standard product to be modified for maximum versatility. See details provided or ask your Hufcor representative for the features you want.



GENERAL SPECIFICATIONS/SERIES 641F

Firewall Individual, Omni-Directional Operable Partitions

PART 1 - GENERAL

1.01 DESCRIPTION

A. General

1. Furnish and install operable partitions and suspension system. Provide all labor, materials, tools, equipment, and services for operable walls in accordance with provisions of contract documents.

1.02 RELATED WORK BY OTHERS

- A. Preparation of opening will be by General Contractor. Any deviation of site conditions contrary to approved shop drawings must be called to the attention of the architect.
- B. All header, blocking, support structures, jamps, track enclosures, surrounding insulation, and sound baffles as required in 1.05 Quality Assurance.
- C. Prepunching of support structure in accordance with approved shop drawings.
- D. Paint or otherwise finishing all trim and other materials adjoining head and jamb of operable partitions.

1.03 SUBMITTALS

- A. Complete shop drawings are to be provided prior to fabrication indicating construction and installation details. Shop drawings must be submitted within 60 days after receipt of signed contract.

1.04 FIRE RESISTANCE

- A. Product shall be Listed by a recognized testing, classification and follow-up agency as a one-hour Special Purpose Fire Door Assembly, after testing for fire resistance per UL 10B.
- B. The listing shall include all variations of panel configuration, tracks, hardware, end conditions, options, finishes, and pass doors contained in project design.

1.05 QUALITY ASSURANCE

- A. Preparation of the opening shall conform to the criteria set forth per ASTM E557 Standard Practice for Architectural Application and Installation of Operable Partitions
- B. The partition STC (Sound Transmission Classification) shall be achieved per the standard test method ASTM E90.
- C. Noise isolation classifications shall be achieved per the standard test methods ASTM E336 and ASTM E413
- D. Noise Reduction Coefficient (NRC) ratings shall be per ASTM C423.
- E. Fire resistance classification: UL 10B
- F. Fire hazard classification: ASTM E84
- G. The manufacturer shall have a quality system registered to the ISO 9001 standards.

1.06 PRODUCT DELIVERY, STORAGE, AND HANDLING

- A. Proper storage of partitions before installation and continued protection during and after installation will be the responsibility of the General Contractor.

1.07 WARRANTY

- A. Partition shall be guaranteed for a period of two years against defects in material and workmanship.

PART 2 - PRODUCTS

2.01 ACCEPTABLE MANUFACTURERS

- A. Upon compliance with all of the criteria specified in this section, Manufacturers wishing to bid products similar to the product specified must submit to the architect 10 days prior to bidding complete data in support of compliance and a list of three past installations of products similar to those listed. The submitting manufacturer guarantees the proposed substituted product complies with the product specified and as detailed on the drawings.

2.02 MATERIALS

- A. Product to be top supported Series 641F individual, omni-directional panels as supplied and installed by GIBCA.
 1. Panels shall be nominally 4" [100] thick and to 48-1/8" [1222] in width.
Optional: Panels shall be 58"-1/2" [1486] in width.
 2. Panel faces shall be of one-piece rollformed min. 20 ga. [.89] steel laminated to gypsum backing and assembled to welded steel frame.
 3. Face finish shall wrap around the vertical panel edges and require no vertical trim.
 4. Frames shall be of min. 16 ga. [1.5] painted steel.
 5. Vertical interlock between panels shall be of tongue and groove configuration and provide panel-to-panel interlock. The lead panel shall

seal against adjacent wall surface with recessed or surface jamps.

6. Horizontal top seals shall be retractable, provide 1" [25] nominal operating clearance, and exert 50 lbs. [22.68 kg] of upward force when fully extended.
7. Horizontal bottom seals (**select one**):
 - a. Horizontal bottom seals shall be retractable, provide 1-1/2" [38] nominal operating clearance, and exert 60 lbs. [27.21 kg] downward force when fully extended.
 - b. Horizontal bottom seals shall be retractable, provide 4" [100] nominal operating clearance, and exert 97 lbs. [44 kg] downward force when fully extended.
8. Horizontal trim shall be of aluminum.
- B. Weight of the panels shall be 9.5-10.9 lbs. per sq. ft. [46.00-53.2 kg. per sq. m] based on options selected.
- C. Suspension system:
 1. **For panels to 1000 lbs. [455 kg] or 22'2" [6.75m]:** Track shall be of clear anodized architectural grade extruded aluminum alloy 6063-T6. Track design shall provide integral support for adjoining ceiling, soffit, or plenum sound barrier. Track shall be connected to the structural support by min. 3/8" [10] dia. threaded steel hanger rods. Track trim shall be of steel.
 - a. Each panel shall be supported by two 2-wheeled counter-rotating horizontal carriers. Wheels to be of precision ground steel ball bearings with heat treated and hardened races encased with molded polymer tires.
 2. **For panels 1000-1500 lbs. [455-680 kg]:** Track shall be of clear anodized architectural grade extruded aluminum alloy 6063-T6. Track design shall provide integral support for adjoining ceiling, soffit, or plenum sound barrier. Track shall be connected to the structural support by min. 1/2" [13] dia. threaded steel hanger rods. Track trim shall be of steel.
 - a. Each panel shall be supported by two 2-wheeled counter-rotating horizontal carriers. Wheels to be of precision ground steel ball bearings with heat treated and hardened races encased with molded polymer tires, steel banded and reinforced.
 3. **For panels 1500-3000 lbs. [680-1364 kg]:** Type 11 track shall be of 1/4" [6] formed black painted steel connected to the structural support by min. 1/2" [13] threaded steel hanger rods. Track trim shall be of steel. Carriers to have four steel wheels with precision ground radial bearings. Bearings are inserted into a steel tire. The steel tire rim fully captures the bearing. Carriers may be programmed for self-directing and sorting.
 4. Optional tracks may be used providing the height and weight limits are within manufacturers guidelines. See page 6 "Optional Tracks".
 5. Plenum closure (by others): Design of plenum closure must permit lifting out of header panels to adjust track height. Plenum closure required for optimum sound control of partition.
- D. Finishes
 1. Face finish shall be (**select as required**):
 - a. Factory applied standard reinforced vinyl fabric with woven backing, weighing not less than 20 oz. per lineal yard. Color shall be selected from manufacturer's standard color selectors.
 - b. Standard upgrade fabrics:
 - (1) Factory applied vertical ribbed carpet (N.R.C. .20)
 - (2) Factory applied stain resistant fabric
 - c. Optional:
 - (1) Customer selected (requires factory approval for manufacturing compatibility-**must have UL label and 15 or less flame spread**)
 - (2) Unfinished for field decoration (**any vinyl, fabric, carpet, or other materials added to the panels must be approved by the local Fire Marshal**).
 2. Frame color shall be black
 3. Horizontal trim shall be (**select one**):
 - a. Brown (standard)
 - b. Gray (standard)
 - c. Custom color (upgrade)
 4. Track trim shall be primed off white.
- E. Available Accessories/Options
 1. ADA compliant pass door of the same thickness and finish as the basic panels.
 - a. Automatic door closer
 - b. Door lock
 - c. Self-illuminated exit sign
 2. Inset chalk/writing/projection surfaces
 3. Inset tackboards
 4. Inset eraser pocket

- 5. Intersecting partitions
- 6. Inset chair rail pan (for field installation of chair rail).
- 7. Pocket doors
- 8. Field sound test

2.03 OPERATION

- A. Panels shall be manually moved from the storage area, positioned in the opening, and seals set.
- B. Retractable Horizontal Seals
 - 1. Retractable horizontal seals shall be activated by a removable quick-set operating handle located approximately 42" [1067] from the floor in the panel edge.
 - 2. Top and bottom retractable seals shall be operated simultaneously.
 - a. 1-1/2" bottom seal activation requires approximately a 190 degree turn of the removable handle.
 - b. 4" bottom seal activation requires a lift/drop motion of the removable handle.
- C. Final partition closure to be by expanding jamb which compensates for minor wall irregularities and provides a minimum of 250 lbs. [113.4 kg] seal force against the adjacent wall for optimum sound control. The jamb activator shall be located approximately 45" [1143] from the floor in the panel face and be accessed from either side of the panel. The jamb is equipped with a mechanical rack and pinion gear drive mechanism and shall extend 4"-6" [100-152] by turning the removable operating handle.
- D. Stack/Store Panels
 - 1. Retract seals with removable operating handle and move to storage area. Panels are stored on stacks in storage area(s).

2.04 ACOUSTICAL PERFORMANCE

- A. Acoustical performance shall be tested at a laboratory accredited by the National Voluntary Laboratory Accreditation Program (NVLAP) and in accordance with ASTM E90 Test Standards. Standard panel construction shall have obtained an STC rating of (select as required): 51 or 54.
 - 1. Complete, unaltered written test report is to be made available upon request.

PART 3 - EXECUTION

- A. Installation.

The complete installation of the operable wall system shall be by an authorized factory-trained installer and be in strict accordance with the approved shop drawings and manufacturer's standard printed specifications, instructions, and recommendations.
- B. Cleaning
 - 1. All track and panel surfaces shall be wiped clean and free of handprints, grease, and soil.
 - 2. Cartoning and other installation debris shall be removed to onsite waste collection area, provided by others.
- C. Training
 - 1. Installer shall demonstrate proper operation and maintenance procedures to owner's representative.
 - 2. Operating handle and owners manuals shall be provided to owner's representative.
 - 3. Upon completion, submit authorized Oversize Certificate as specified by testing, classification, and followup agency.

Header construction by others. Must meet or exceed one hour fire rating.

Shown with Type 36 Aluminum track. Standard for weights to 1000 lbs. [455 kg].

VERTICAL SECTION

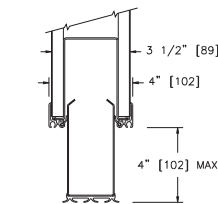
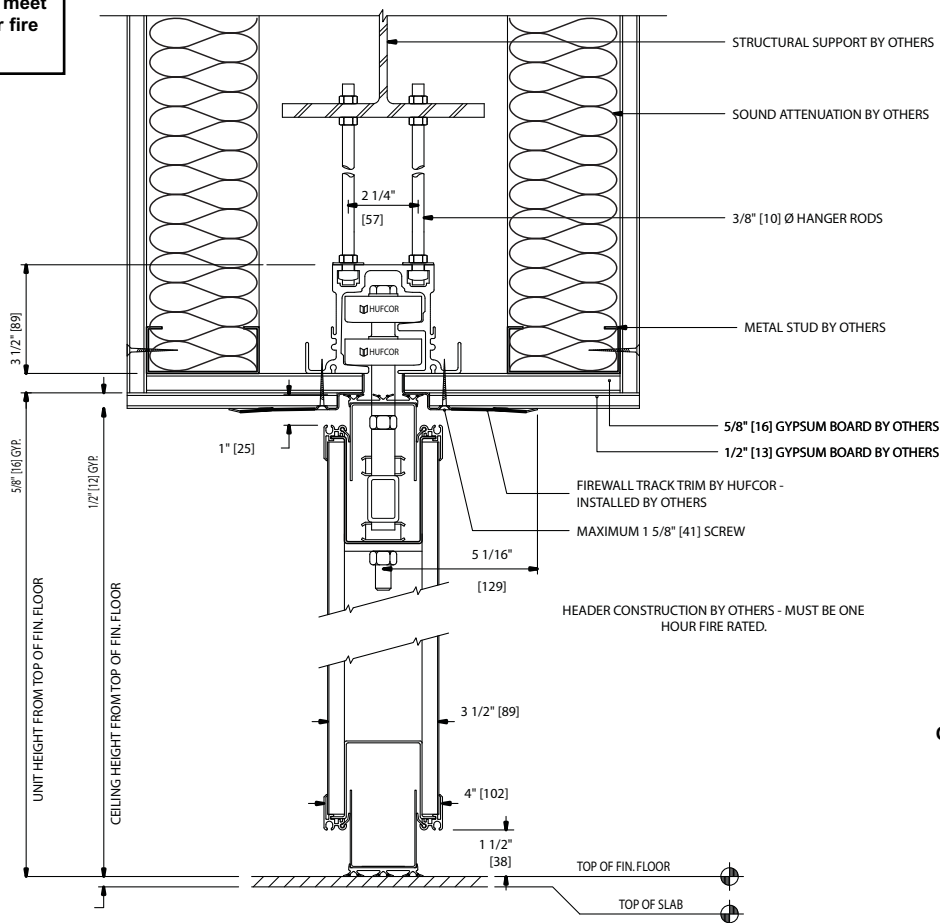

Optional Bottom Seal: 4" clearance

No Scale



Firewall, Individual, Omni-Directional Operable Partitions

HORIZONTAL SECTION

Final partition closure with expanding jamb. Solid blocking required at both ends to withstand 250 lbs. [113.4 kg] of lateral force.

Final partition closure using surface wall jambs.

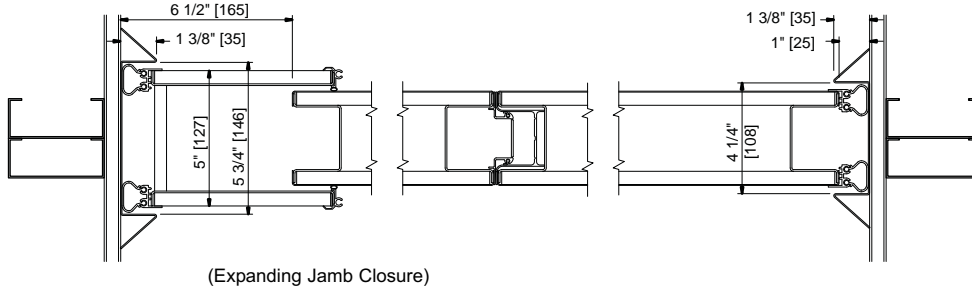

Final partition closure using wall recesses.

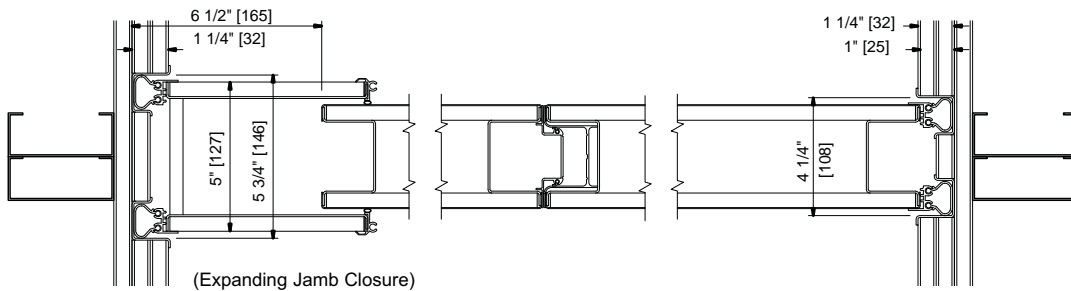

No Scale

OPTIONS & ACCESSORIES

ELEVATION

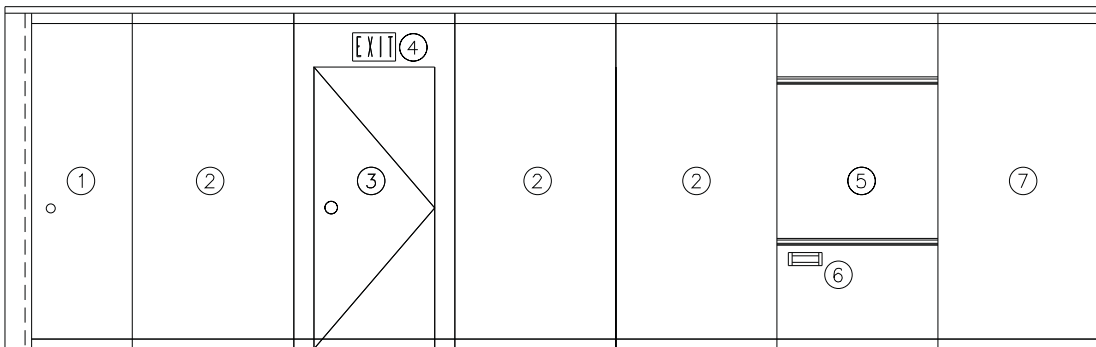

1. **Expanding Jamb Closure panel.** Expanding jamb exerts 250 lbs. [113.4kg] force against adjacent wall for optimum sound control.
2. **Basic panel**
3. **ADA compliant pass doors** - Single 3/0 x 7/0 [914 x 2132] or 3/0 x 6/8 [914 x 2030]. Of the same construction, thickness, and finish as the basic panels. Push/pull latching handle. Options include key lock, windows, and automatic door closer. No threshold is required.
4. **Exit Sign** - Recessed, self-illuminated.
5. **Work Surfaces** 4'0" [1219] high x panel width, recessed, mounted approx. 30" [762] above the floor:
 - a. Inset chalkboard and projection/writing surfaces.
 - b. Tackboards of 2mm cork board covered with textured vinyl fabric (from Hufcor standard color selector).
 - c. Chalk/marker tray (standard on chalk and projection/writing boards).
6. **Recessed Eraser Pocket** (8" x 2" x 1-1/4" deep [203 x 50 x 31]).
7. **Lead panel** with bulb seal to prevent sound leaks at adjacent wall.

Firewall, Individual, Omni-Directional Operable Partitions

Stack Dimensions

The following stack depth and width dimensions are based on a flat stack and standard construction with vinyl faces. Angled stacks require additional space. Contact your Hufcor Distributor for angled stack requirements. Optional construction and/or face covering may increase stack dimensions.

- Stack Depth: 4-1/4" [108] per panel plus 1-1/2" [32]
Optional panic hardware will add to the depth of the stack. Please contact your Hufcor distributor for assistance.
- Stack Width: Panel width + 12" [300] clearance.
- For Pocket Storage: Due to the wide variety of stack configurations possible, consult your Hufcor representative for space requirements.

TYPE 1

The Type 1 stack shown above is the most often used for simple omni-directional layouts. Following are additional common stack configurations. Stacks are not limited to these configurations and may be built to fit each job requirement. Consult your Hufcor representative for design assistance.

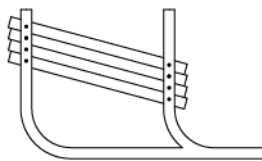
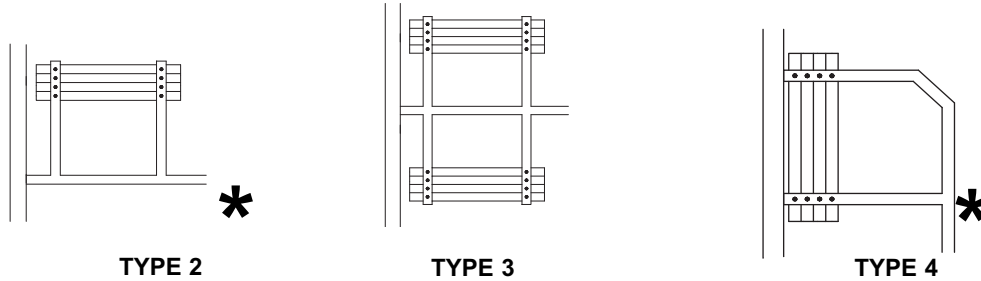

* TYPE 7

Type 11 steel track uses curves, diverters, switches for easiest movement of very tall/heavy panels. The carriers may be programmed for self-directing and sorting.

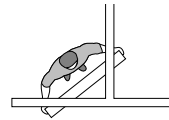

* CAUTION

Body space is needed to access the panels and move them into position. Be certain to consult your Hufcor representative before constructing walls in pocket/stack areas. This is important for all configurations, but can be especially important with those stacks marked with an asterisk.

OPTIONAL INTERSECTIONS - In order to be Classified as a one-hour fire-resistant product, all jambs, panels, tracks, intersections, and other options or features must be included in the Classification listing. **INSIST** on seeing the manufacturer's listing from the recognized testing agency. Following are common styles of Hufcor Firewall intersections included in our classification listing.

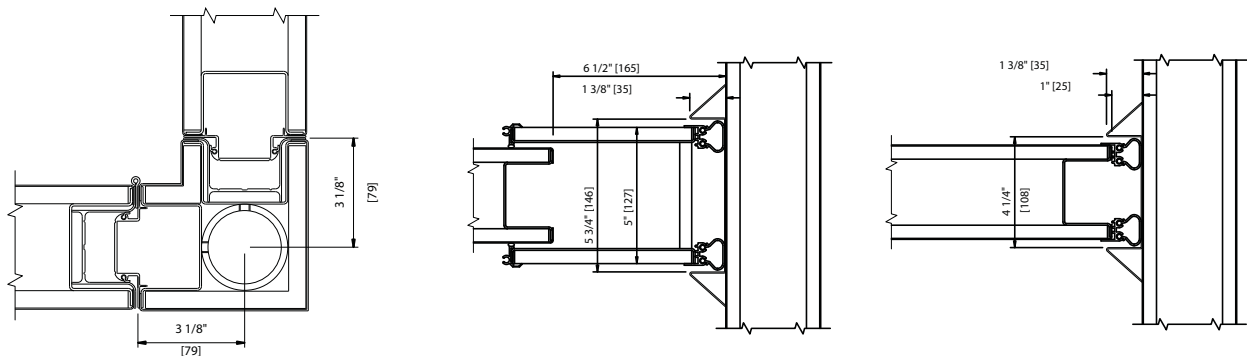

2-Way Multiple Meeting Post At 135 Degrees and other custom angles are available.



Hanging Weight		
STC	Lbs./Sq. Ft.	Kg/Sq. M
51.0	9.5	46.0
54.0	10.9	53.2

OPTIONAL TRACKS - Alternate Hufcor track systems may be used providing the height and weight limits are within manufacturer's guidelines.

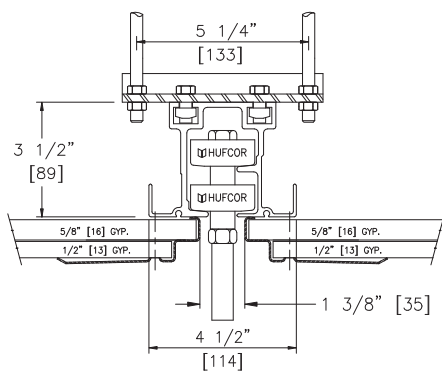

Type 26 Aluminum Track

for panel weights to 500 lbs. [227 kg]. Each carrier has two horizontal counter-rotating wheels. Each wheel has precision ground bearings, encased with Delrin for quiet operation. Minimum dimension from the ceiling to the structure is 8" [203]. Shown with optional suspension bracket available for 5-1/4" [133] spacing. Suspension bracket is available for all aluminum tracks.

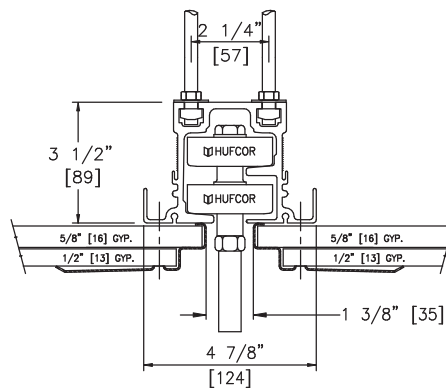

Type 36 Aluminum track.

Standard for weights to 1000 lbs. [455 kg]. Each carrier has two horizontal counter-rotating wheels that roll in the track. Each wheel has precision ground bearings encased with Delrin for quiet operation.

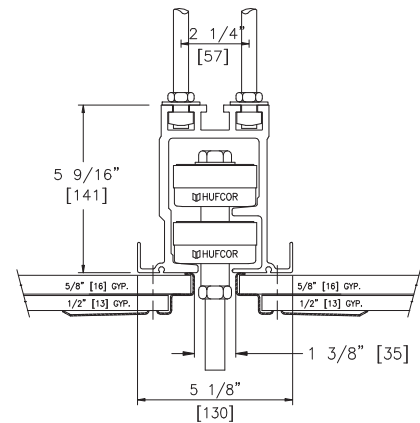

Type 57 Aluminum Track

for panel weights to 1500 lbs. [682 kg]. Each carrier has two horizontal counter-rotating wheels. Each wheel has precision ground bearings, encased with Delrin, steel banded and reinforced. May be programmed for self-directing and sorting. Minimum dimension from the ceiling to the structure is 12" [305].

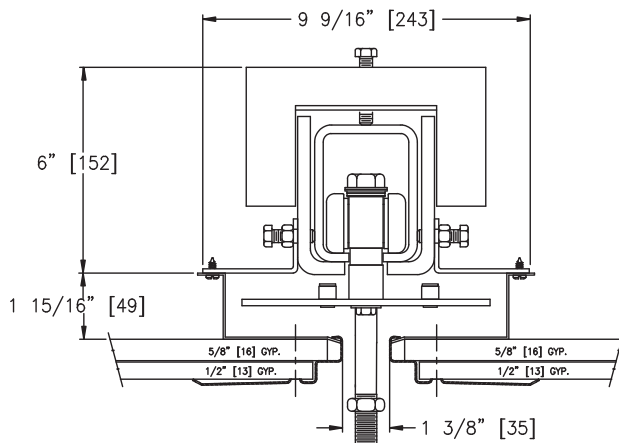

Type 11 Steel Track

For panel weights to 3000 lbs. [1364 kg]. Required for panels over 1500 lbs. [682 kg]. Track is of 1/4" [6] formed steel. Track trim is steel. Curves, diverters, or switches are available. Each carrier has four steel wheels with precision ground radial bearings. Bearings are inserted into a steel tire. Tire rim fully captures the bearing. Carriers may be programmed for self-directing and sorting. Minimum dimension from the ceiling to the structure is 12" [305].

Hufcor reserves the right to improve and change product without notice.



P. O. Box 20923, AJMAN - UAE
 Tel : +971-6-7436888, Fax : +971-6-7436903
 E-mail : info@gfiuae.com
 website: www.gfiuae.com